

STAR
Quality First

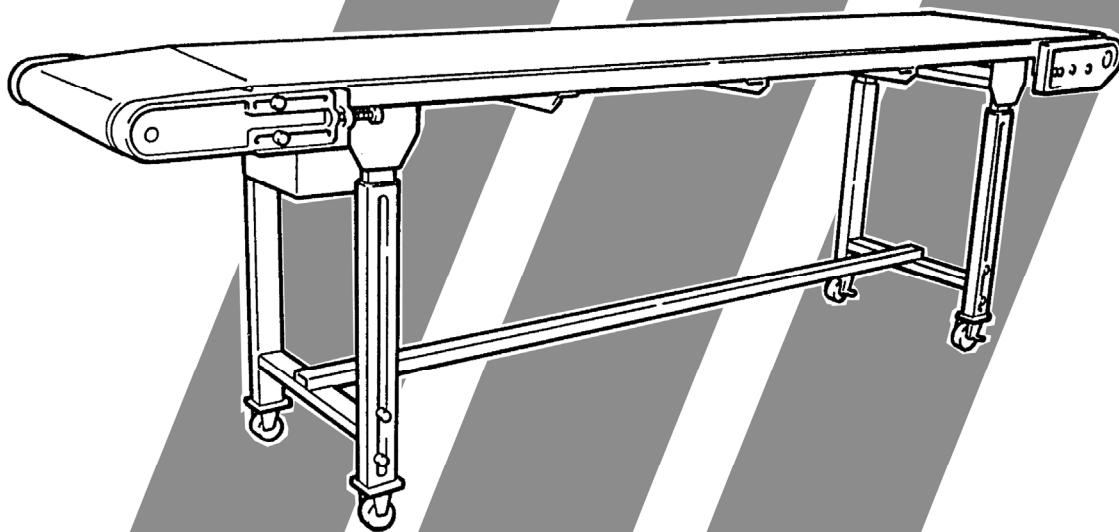

**Pool Conveyer
PC-CCZ
Instruction Manual**



STAR SEIKI CO., LTD.

INTRODUCTION

Thank you for purchase of the Star Conveyer “Pool Conveyer”. This manual describes the machine's functions and presents important information about operating methods and precautions. Please read through this manual carefully so that you will be able to use the machine safely and effectively. Keep this manual in a place of easy access.

Feature

- Best-suited for medium-size and large-size injection molding machines and for long-time stocking.
 - Regular maintenance is not almost required with the geared motor and the chain.
 - Interlock operation with devices such as an unloader with external signals allows intermittent operation of the conveyer. And the movement dimension of the product can be changed easily.
 - The conveyer can be used not only for conveyance and stocking but for a simple workspace.
 - Using synthetic-resin belt reduces surface flaws and stains on the product. And it has high heat and oil resistance. Also it prevents electrostatic buildup. So the conveyer is suitable for plastic molding.
-

CONTENTS

1. PRECAUTIONS

1-1. Safety-Precaution Indications	1
1-2. Safety Precautions	2
1-3. Caution plates	7
1-4. Mechanical Specifications	8

2. FEATURES AND THEIR LOCATIONS

2-1. Overview	9
2-2. Control box (Control panel)	11

3. MECHANICAL ADJUSTMENTS

●Adjusting the height	12
●Adjusting the belt tension	12
●After making the adjustments	13
●Maintenance	13

4. PARTS LIST

14

5. WARRANTY AND AFTER-SALE SERVICE

15

6. ELECTRIC CIRCUIT DIAGRAM

16

7. OVERALL DIAGRAM



17

1. SAFETY-RELATED INFORMATION

1-1. Safety-Precaution Indications

■ Danger Level Symbols

The safety precautions in this manual are classified into the following three levels.

 DANGER	Failure to follow this safety precaution may result in great physical danger to the operator, or even death.
 WARNING	Failure to follow this safety precaution may result in great physical danger to the operator, or severe damage to the equipment.
 CAUTION	Failure to follow this safety precaution may result in injury to the operator, or damage to the equipment.

■ About Important Points

Important points on handling are indicated with  in the manual.

1-2. Safety Precautions



DANGER

PROHIBITING WORKER TO RIDE ON CONVEYER

Never attempt to ride on the conveyer. If the worker rides on the conveyer, it may cause the risk of making the conveyer unstable and so fall down, getting the worker injured.

DO NOT PERFORM MAINTENANCE WHILE CONVEYER IS RUNNING!

Never attempt to service or perform maintenance on the conveyer while it is running. Before carrying out maintenance, be sure to shut down the machinery as follows: (1) Shut down the air supply. (2) Switch off the POWER switch in the control box. (3) Cut the power breaker.



WARNING

Wear appropriate work clothes.

Do not wear bulky clothing and accessories when working at the conveyer, as these may be caught in the machinery, getting the worker seriously injured.

Do not attempt to modify the conveyer.

Do not redesign, rebuild, or otherwise modify the conveyer. The manufacturer cannot be responsible for accidents or damage caused by modified equipment.

Be sure to ground the conveyer.

Use a No.3 ground setup to help reduce the risk of electric shock at installation. Also, after moving the conveyer to another place or performing periodic inspection, make sure that the specified ground setup has been done.

Use a non-fuse circuit breaker.

To avoid the risk of fire due to overcurrent, include a non-fuse circuit breaker in the wiring leading to the power source.

Do not open the cover on the power box.

High voltages are present within the power box. Opening the cover may lead to serious electric shock.

Do not remove the chain cover for operation.

Operating the conveyer with the chain cover removed may cause the risk of getting the worker caught or pinched in the machinery.

Do not touch the conveyer belt while it is running.

Never put your hands inside the conveyer belt while it is moving. Doing so may cause the risk of getting your hands caught or pinched in the conveyer driving rollers.

Shut down operation during periods of frequent power outage.

The machinery should be shut down during times when power supply is frequently going off due to thunderstorm or other such external event. Operating with an irregular power supply may lead to equipment damage. If you cannot locate the cause of failure, please contact the engineering service personnel of our sales office.



CAUTION

Confirm mutual safety in the case of cooperated work.

When two or more persons jointly work together, be sure to clarify who is responsible and confirm safety by pointing the finger to all safety confirmation places and saying “O.K” if safe before getting operation started, in order to avoid accidents due to miss-operation or safety confirmation failure at manual adjustment.

Secure adequate maintenance space.

For safe operation, please leave at least 1 meter of maintenance space (with empty floor) around the circumference of the conveyer.

Work under bright illumination.

To ensure that work is done safely in setting the conveyer and performing service or maintenance, be sure to work under bright illumination.

Carry out daily maintenance inspections.

Check machinery daily to make sure it is in safe operating condition. Contact STAR SEIKI in the event of problem.

Stop working in the event of breakdown or other problems.

If you think that the conveyer is abnormal or malfunctioned, do not keep working based on your own thought. Simply stop operating it. Be sure to get operation started on the basis of appropriated instructions from our engineering service personnel.

Never touch the switches with wet or dirty hands.

Doing so may cause the risk of not only getting the conveyer malfunctioned but also accidents due to electric shock.

Stop all devices linked to the conveyer during operation.

Before carrying out inspection, repair, adjustment, cleaning or lubrication work in the conveyer's moving range, be sure to shut down not only the conveyer itself but also all devices linked to it, such as your molding machine, etc. A failure to do this may cause the risk of getting the worker seriously injured due to unexpected drive.

■ Kinds of Caution Plates

* Note that some of the caution plates given below are not used on the conveyer.

● Caution for high voltage electrical shock



Make sure to cut off the breaker of controller while maintenance work is being done. Especially during such work for inside the box, disconnect connecting cable with molding machine and cut off primary power supply of the factory.

This label can be found at the locations (terminal block, etc.) where special attention is required in the range of high voltage warning.

● Caution for danger of enfolding



To work in moving zone for maintenance or other purposes, do not touch carelessly with such parts as motor, rotary axis, gear, pulley, belt which have danger of enfolding you. Cut off power supply and air pressure to work.

● Caution for static electricity

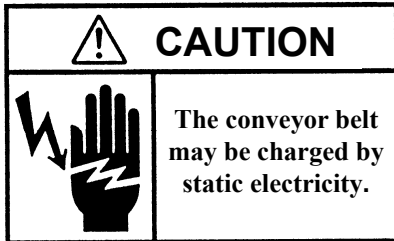

The conveyor belt or the product on the conveyor may be charged by static electricity. You may be shocked by electric when approaching.

1-3. Caution plates

The following diagram shows the location and content of caution plates affixed to the conveyer.

■ Example of caution plates disposition

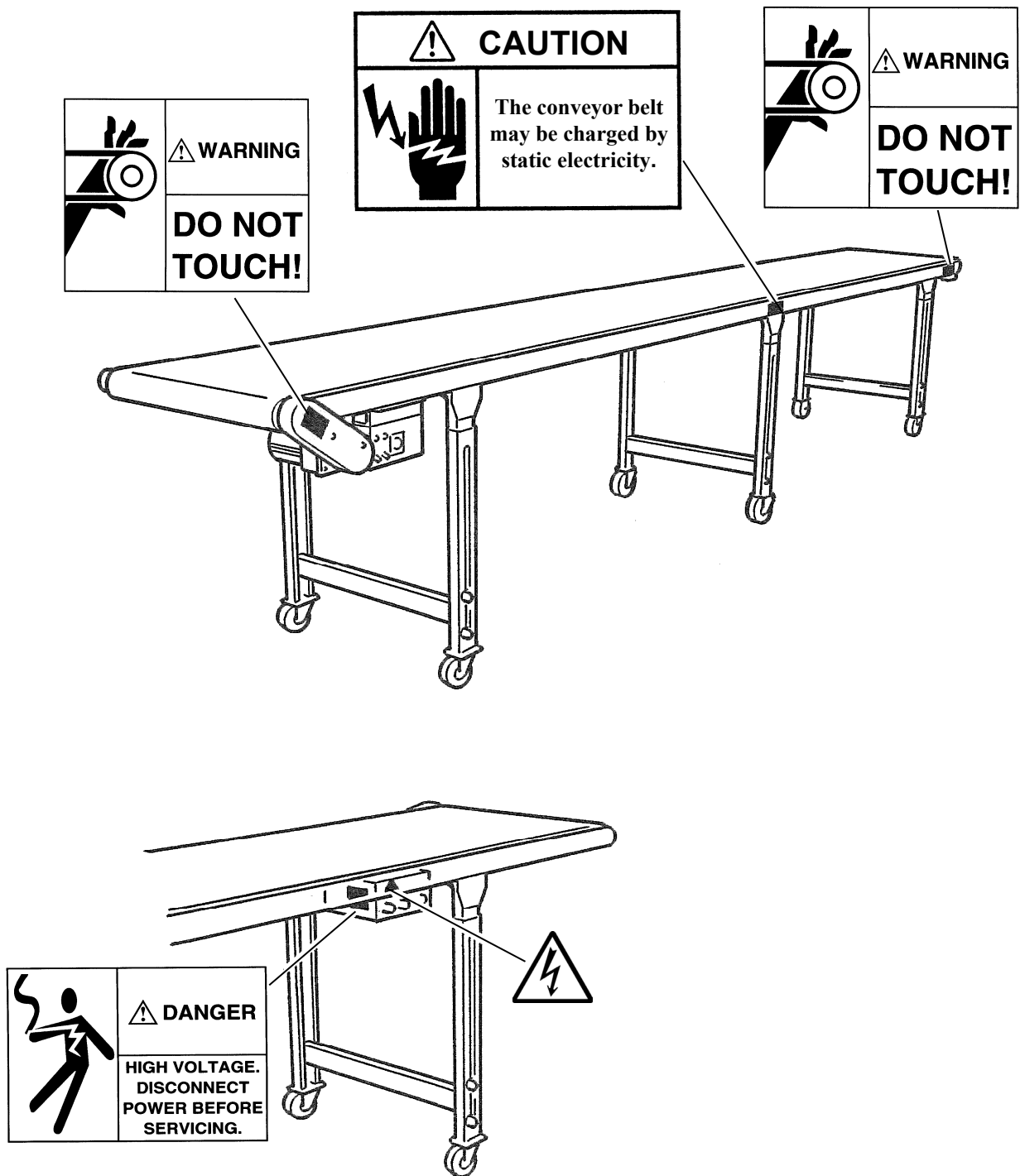

1-4. Specifications

Model

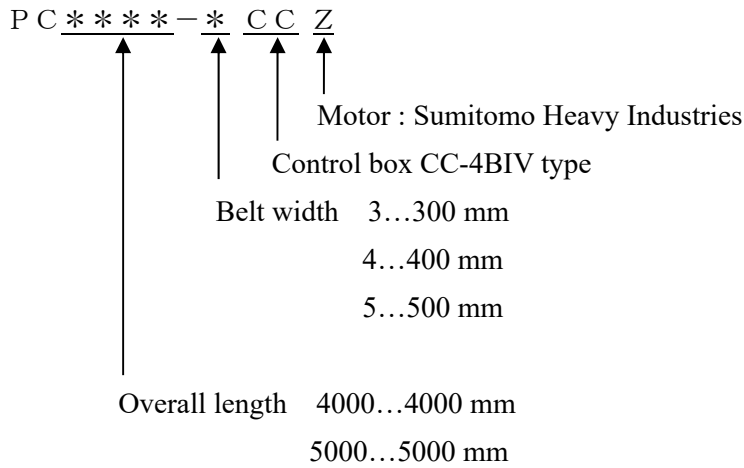

Height m/m	900~1300 Free adjustment
Power consumption	AC200V 60W(90W)
Speed	1~4 m/min (60HZ)
Maximum transport weight (horizontal position)[kg]	70
Overall weight [kg]	See accompanying table.
Optional specifications	1002-02 feet + variable speed specifications (1~8 m/min 60HZ)

●Overall weight (Kg)

Belt width \ Overall length	3CCZ	4CCZ	5CCZ	6CCZ	7CCZ	8CCZ	9CCZ	10CCZ
PC4000-	108	114	120	126	132	138	144	150
PC5000-	128	134	140	146	152	158	164	170
PC6000-	148	154	160	166	172	178	184	190

2. PARTS AND FUNCTIONS

2-1. Overview

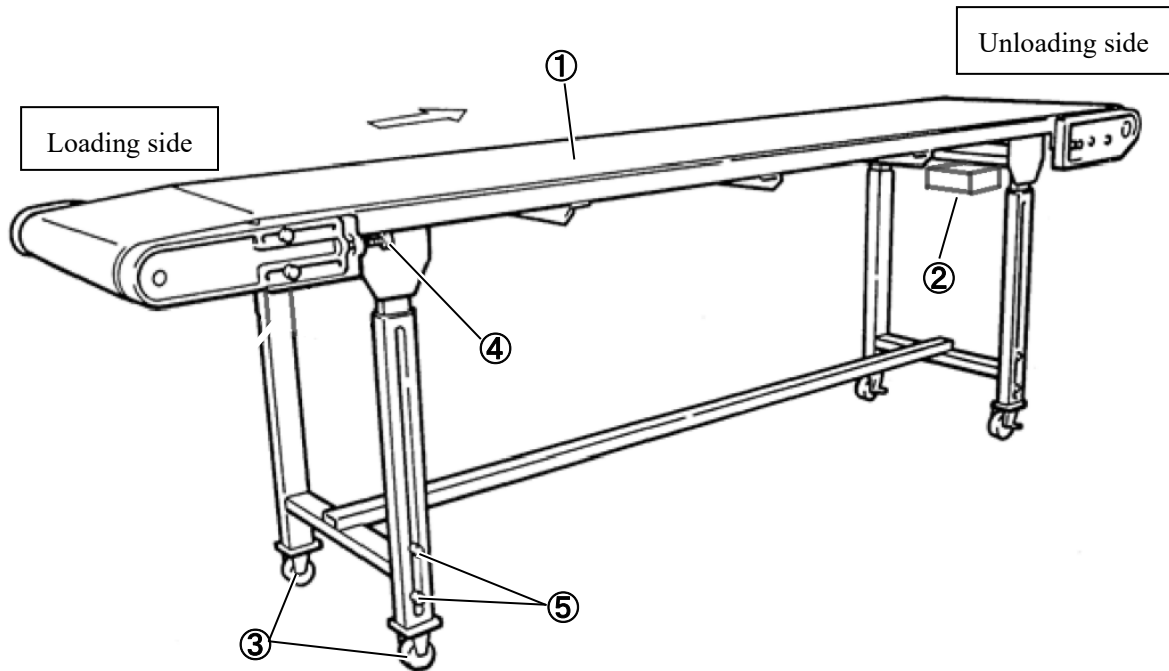

① Conveyor belt

This belt is made from synthetic resin which offers static-electricity prevention and oil/heat resistance.

② Control box

Controls the conveyer drive status.

③ Caster

Use these casters to move the conveyer belt. Lock each caster using the stopper after installation.

④ Tension adjustment bolt

Use this bolt to adjust the loosened conveyer belt. After adjustment, tighten the bolt securely.

* Do not adjust the belt too tightly.

* Adjust both bolts equally.

⑤ Height adjustment handle

Loosen this handle to adjust the height of the conveyer stand. Be sure to lock this handle after adjustment.

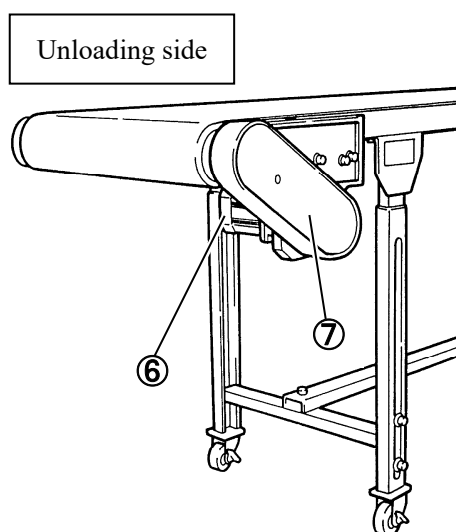

⑥ Motor gear reduction unit

This is the drive source of the conveyer, with a speed of 1 to 4 m/min (60HZ) [standard type].

* You can reverse the conveyer transport direction by switching the motor wiring. Consult the nearest Star office before you switch the wiring.

⑦ Chain cover

Remove this cover to adjust and check the chain sprocket.

2-2. Control Box (Operation Panel)

■ Standard type(CC-4BIV)

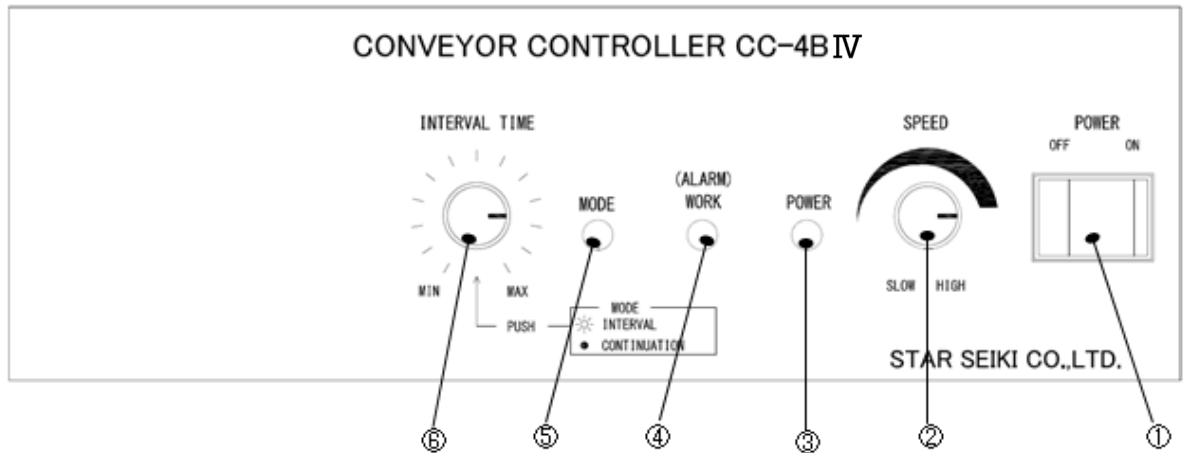

1. Power Switch

Turn on/off the power of conveyor

2. Speed Setting Switch

This switch is used to set the speed of product delivery.

Setting range: 1~4m/min

Note: this speed is measured at a frequency of 60Hz.

3. Power LED

This LED is on when turning on the power.

4. Working LED

The green LED is on when conveyor works normally. The green LED flashes when alarming.

5. Mode LED

This LED is on when conveyor works in interval mode.

6. Mode Selecting Switch

This switch is used to shift modes (Press)

- INTERVAL.....Conveyor start signal is input from an Unloader. Conveyor works in the setting time of timer.
- CONTINUATION.....The conveyor works continuously.

Product Delivery Timer (Rotate)

After pressing switch No.6 and select interval mode, please rotate the switch No.6 to set the time interval for the conveyor to deliver products.

Use this knob to set the product feed speed.

Conveyor speed specified range: 0.25 to 3 m/min (1 to 3 Recommended)

Note : The speed is for 60 Hz.

3. MECHANICAL ADJUSTMENTS

After the location of the unit is decided, lock the casters and perform the following adjustments:

● Adjusting the height

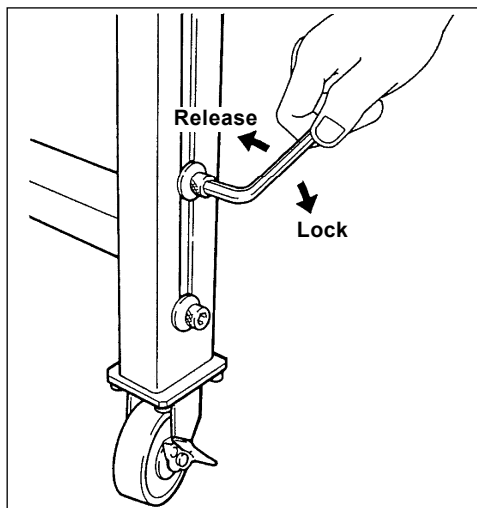

Use the hexagonal wrench to loosen the height adjustment bolts located on the stand legs near the casters (2 bolts × 4 positions), and adjust the height of the conveyor belt.

* After adjustment, tighten the handles securely.

● Adjusting the belt tension

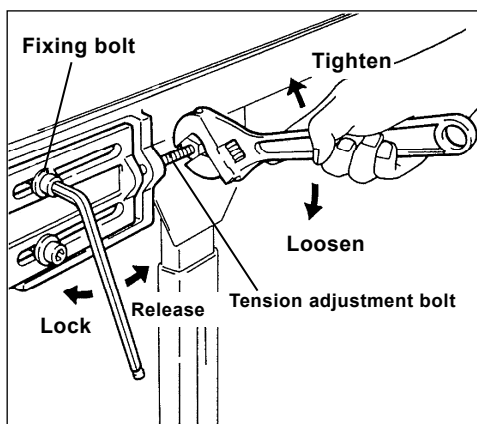

Adjust the belt tension only when the conveyor belt weaves or when the conveyor driving roller is rotating without transporting the belt. Otherwise, you do not need to adjust the belt tension.

Loosen the fixing bolt on each side of the unloading end, and adjust the belt tension using the tension adjustment bolt.

* Do not adjust the belt too tightly.

* Adjust both bolts equally.

* Tighten the fixing bolt securely after adjustment.

●After making the adjustments.....

① Wire the power and conveyer start signal.

- * Shut off the power on the supply side (primary side) during the wiring operation.
- * Refer to the instruction manual that came with the control box of the unloading machine for the wiring of the conveyer start signal (SG1, SG2).

Consult the nearest Star office before you try to input the conveyer start signal from a machine other than a Star unloading machine.

② Insert the metal connectors to the rear panel of the control box.

- * Shut off the power on the supply side (primary side) when removing/inserting the metal connectors.

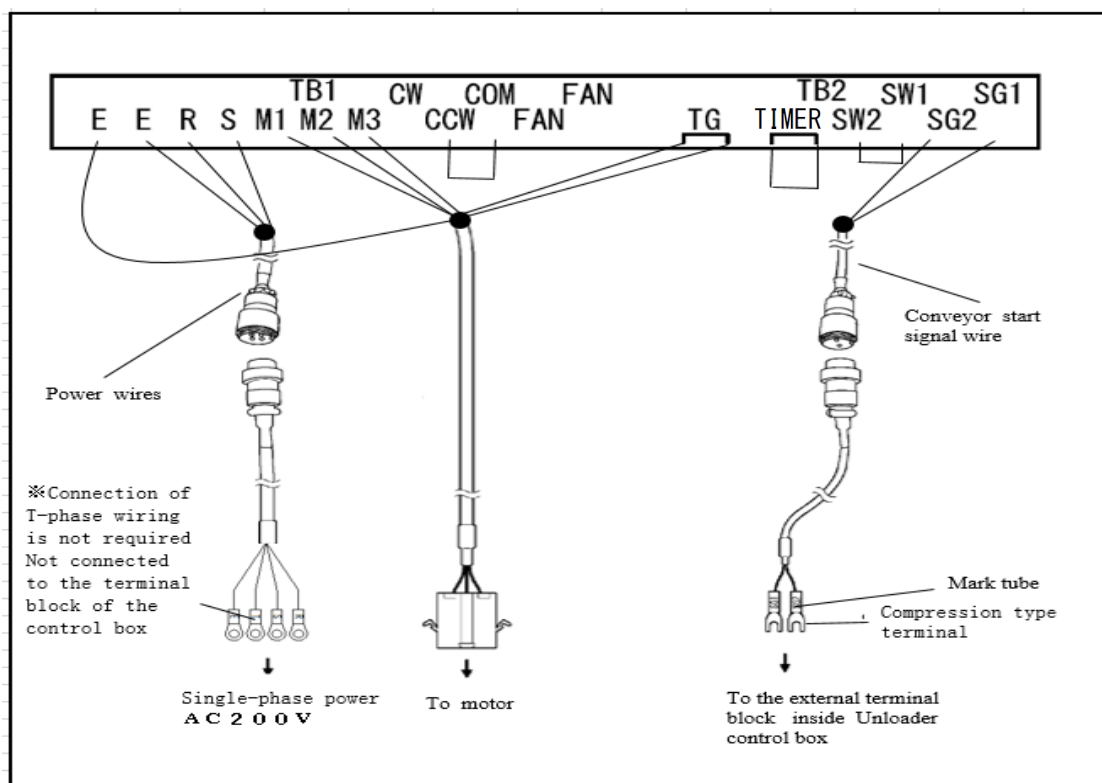

●Maintenance

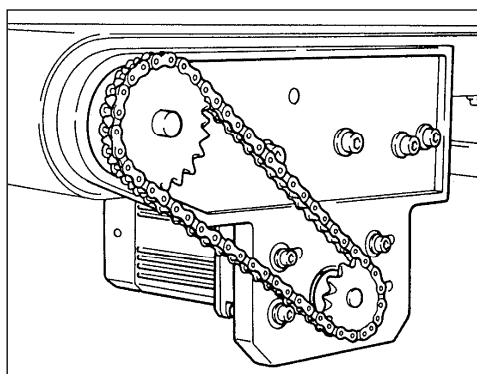

Remove the chain cover to apply grease to the chain once every six months.

- * Install the chain cover after applying grease.

4. PARTS LIST

Name	Type	Manufacturing	Qty
Motor (AC200V) (See accompanying table.)	A9U60CH (60W)	Sumitomo	1
	A9U90CH (90W)	Sumitomo	1
Condenser	DMF45505 (60W 200V)	Sumitomo	1
	DMF45705 (90W 200V)	Sumitomo	1
Gear head	G9C100KH	Sumitomo	1
Motor (OP AC100V)	A9U60AH (60W)	Sumitomo	1
	A9U90AH (90W)	Sumitomo	1
Condenser (OP)	DMF252006 (60W 100V)	Sumitomo	1
	DMF252406 (90W 100V)	Sumitomo	1
Gear head (OP 1~8m/min 60HZ)	G9C50KH	Sumitomo	1
Conveyer belt	SL-F1502 ****_***	BANDO	1

●Motor capacity

Belt width Overall length	3CCZ	4CCZ	5CCZ	6CCZ	7CCZ	8CCZ	9CCZ	10CCZ
PC4000-	60W	60W	60W	60W	60W	90W	90W	90W
PC4500-	60W	60W	60W	60W	60W	90W	90W	90W
PC5000-	60W	60W	60W	60W	90W	90W	90W	90W
PC5500-	60W	60W	60W	60W	90W	90W	90W	90W
PC6000-	60W	60W	60W	90W	90W	90W	90W	90W

5. WARRANTY AND AFTER-SALE SERVICE

For information about repairs and other service, refer to the nearest STAR SEIKI business office.

■ Warranty

1. The term of the warranty specified by the contract shall begin upon purchaser's approval of the delivered machine. In principle, the term of warranty shall be six (6) months.
2. Breakdowns that occur within the term of warranty period shall be repaired free of charge, with the exceptions noted immediately below.
3. The following are not covered by the warranty.
 - Breakdown caused by inadequate maintenance or inspection.
 - Damage caused by improper handling of the machine.
 - Damage caused by fire or natural disaster (act of God).
 - Damage related to expendable components (chucking parts, etc.)
 - Damage caused by modification or attempted repair carried out by user. (Refer to Section 1-5 for machine specifications.)

7. OVERVIEW

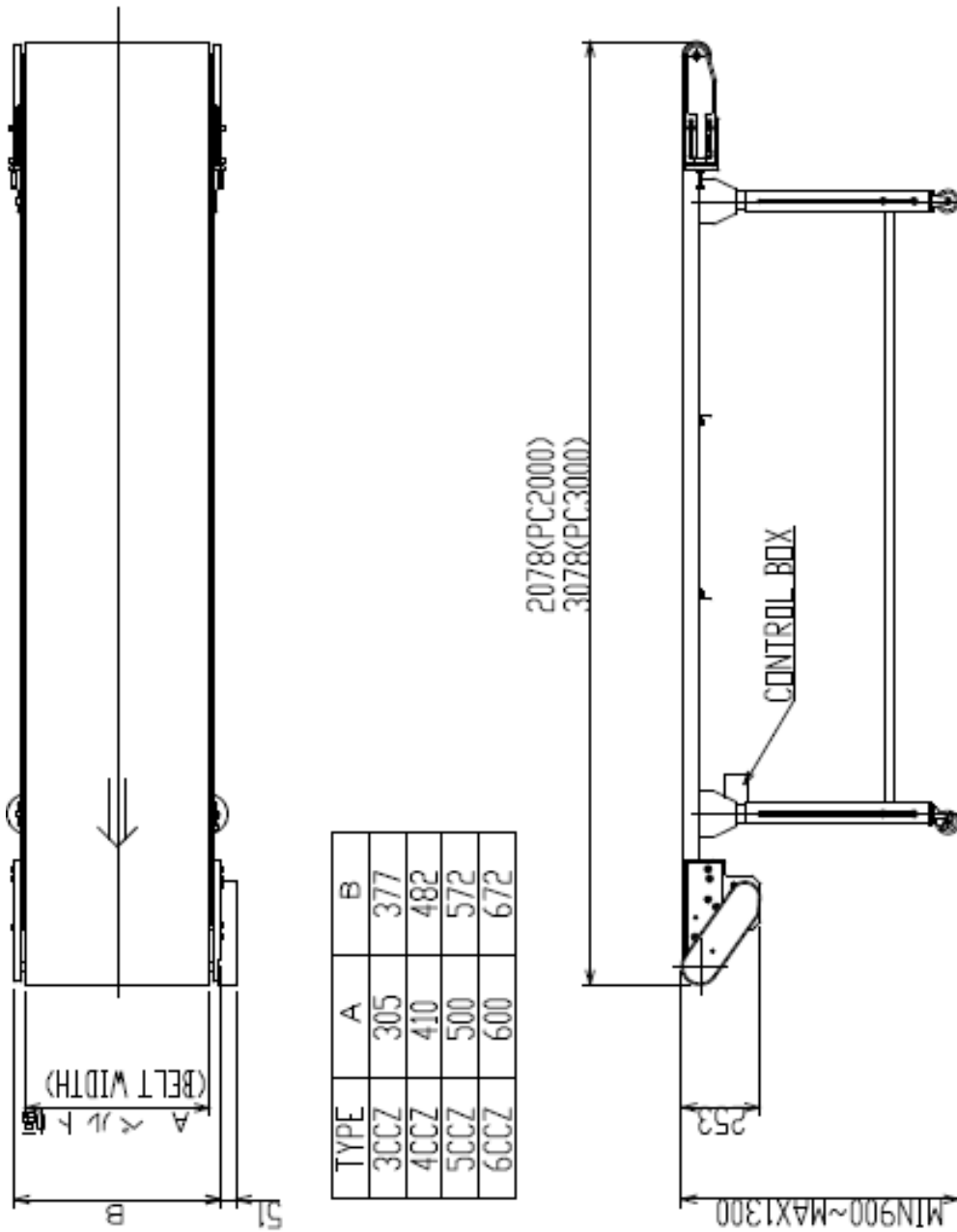

6. OVERVIEW

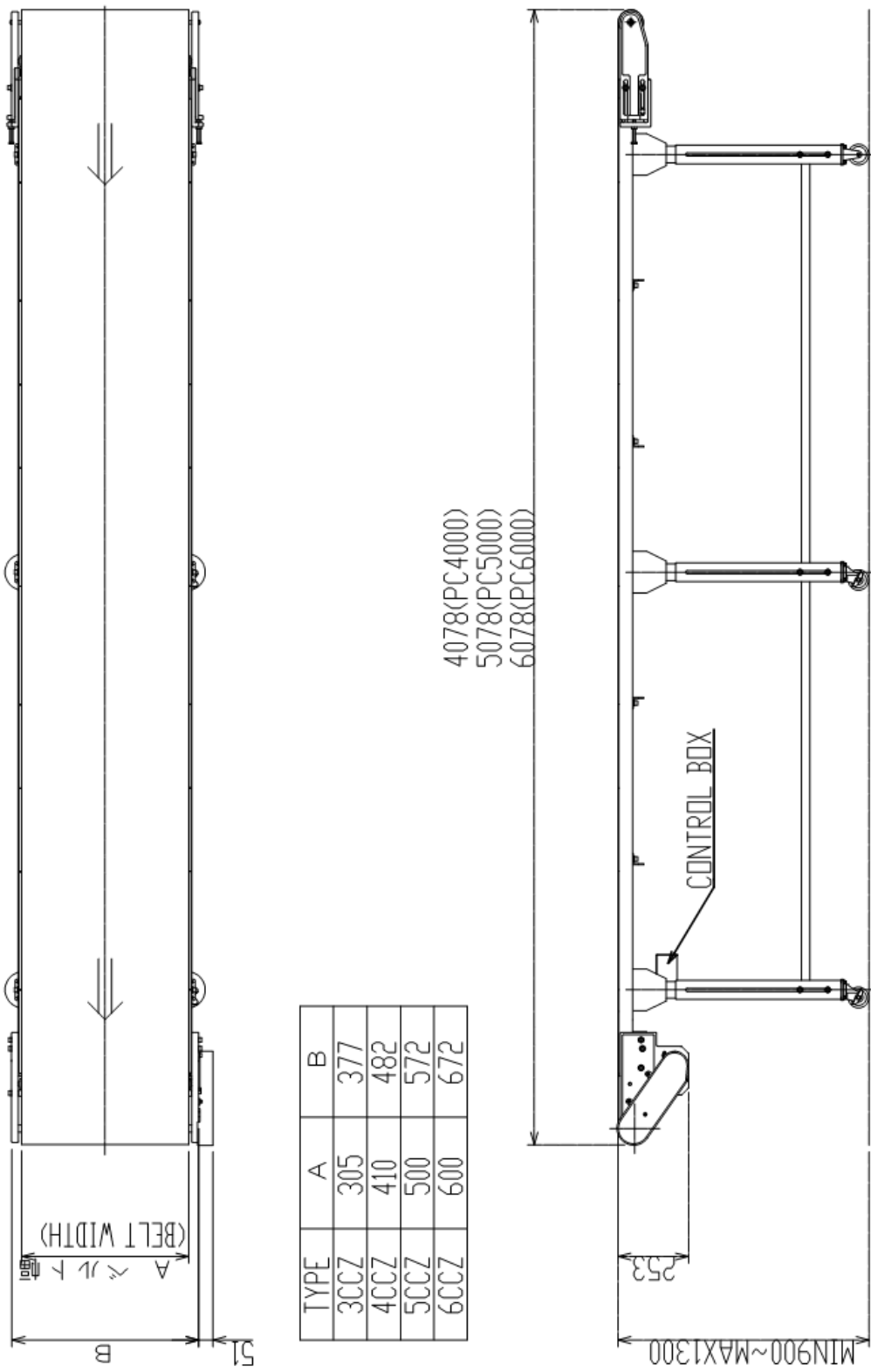

- All copyrights regarding this manual belong to STAR SEIKI Co., Ltd.
Reproduction, translation or adaption of this manual in whole or part without consent from STAR SEIKI shall be an infringement of copyright.
- These specifications are subject to change without prior notice.

for more information

www.starseiki.com

STAR SEIKI CO., LTD.

Head Office / International Division: 3-133, Akita, Ohguchi-cho, Niwa-gun, Aichi Pref., 480-0132, JAPAN
PHONE: 0587-95-7572 FAX: 0587-95-7573

- U.S.A. **STAR AUTOMATION, INC.** PHONE: 262-253-3550 FAX: 262-253-3559
- Singapore **STAR SEIKI SINGAPORE PTE. LTD.** PHONE: 6219-1348/7 FAX: 6219-1349
- Taiwan **STAR SEIKI TAIWAN, INC.** PHONE: 02-2836-0039 FAX: 02-2835-9987
- China **STAR SEIKI (HONGKONG) CO., LTD.** PHONE: 2687-6745 FAX: 2690-4322
- China **STAR SEIKI (SHANGHAI) CO., LTD.** PHONE: 021-6432-6452 FAX: 021-6432-6561
- Europe **STAR AUTOMATION EUROPE S.P.A.** PHONE: 0041-57-85-311 FAX: 0041-57-85-312
- Malaysia **STAR SEIKI (SINGAPORE) PTE. LTD. K.L. BRANCH** PHONE: 03-5882-0211 FAX: 03-5882-0212
- Thailand **STAR SEIKI (THAILAND) CO., LTD.** PHONE: 02-651-0285 FAX: 02-651-0288
- Brazil **STAR SEIKI BRASIL LTDA.** PHONE: 011-3326-3349 FAX: 011-3326-0331

1 5 2 7 6 6

2 6 0 4 - 0 2 - E n g