

微細成形品取出対応

TZWD-750P

TZWD-750SP



型締力 Injection Press Range
20~40ton



片持ち前後フレーム
Cantilever Crosswise Frame



スチールフレーム
Steel Frame



自立型
Independent Type



駆動軸数: 4 / 2
The Number of Servo Axes



LMガイド
LM Guide



コントローラー
STEC-520B
Controller

主仕様 Main Specifications		TZW-500P	TZW-500SP
電源	Power Source	AC 200~220V ± 10% (50/60Hz)	
常用空気圧	Air Pressure	0.5 MPa	
駆動方式	Drive System	ACサーボモータ / AC Servo Motor	
姿勢(エアシリンダ)	Posture (air cylinder)	90°固定 / 90°Fixed	
電源設備容量	Electric Consumption	1.2 KVA	2.4 KVA
最大消費電力	Max Power Consumption	0.7 KW	1.3 KW
エア消費量	Air Consumption	0.37 Nℓ/cycle	0.38 Nℓ/cycle
制御BOX	Control Box	STEC-520B	

●エアシリンダ推力(エア圧力: 0.5Mpa時) Air Cylinder Driving Force (Air Pressure at 0.5 MPa)

最大可搬重量	Max. Load	2 kg (チャック重量含 Incl Chuck Weight)	
姿勢トルク	Posture Torque	3.7 N・m	

●ストローク(移動量) Stroke

製品側取出進入	Product Side Arm Entry	750 mm	
ランナー側取出進入	Runner Side Arm Entry	—	750 mm
製品側前後	Product Side Crosswise Reach	15~315 mm	124~289 mm
ランナー側前後	Runner Side Crosswise Reach	—	56~221 mm

●本体重量 Net Weight

本体	Main Body	165 kg	189 kg
操作ペンダント	Pendant	1.1 kg	

◎ [] はオプション仕様です。

◎ 本体重量は、インターロックBOX・ドライバBOX・ボックス間ハーネスを含む。

◎ Figure in [] shows option.

◎ Net weight includes the weights of interlock box, driver box and cables between control boxes.

For FINE MOLDED PRODUCTS

サイドエントリー型取出口ロボット (横型射出成形機用)
Side-entry type take-out robot (for Horizontal injection molding machine)

TZWD-750P

2プレート金型対応機
For 2 plate mold plate

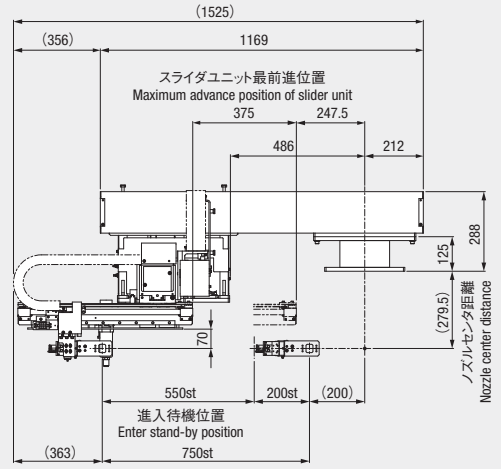
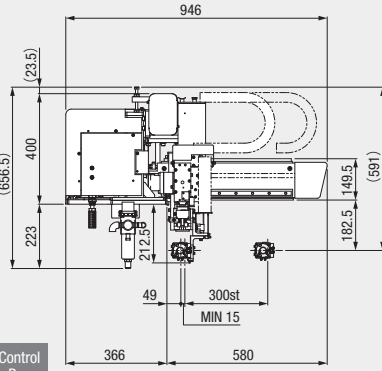
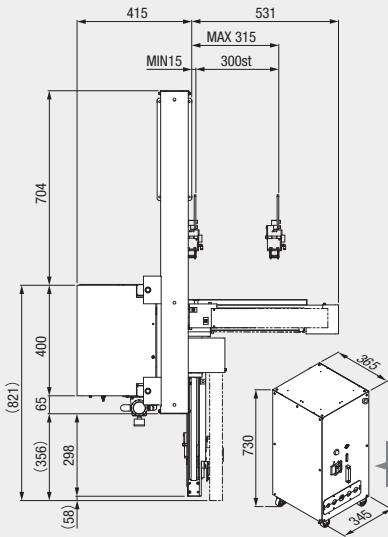

TZWD-750SP

3プレート金型対応機
For 3 plate mold plate

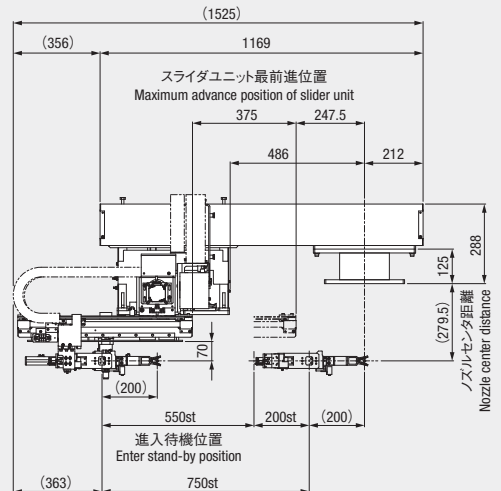
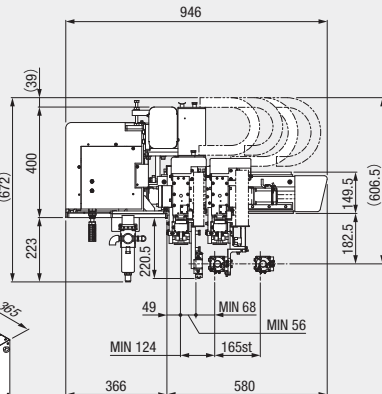
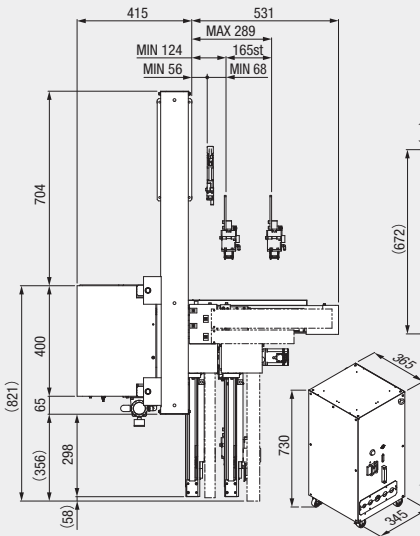

OPTION

金型回避 Collision-avoidance Design with Mold Plate

A 取出時の固定ボルト (2箇所)
One mounting bolt (x2)

B ヒンジ回転軸
Hinge rotation axis

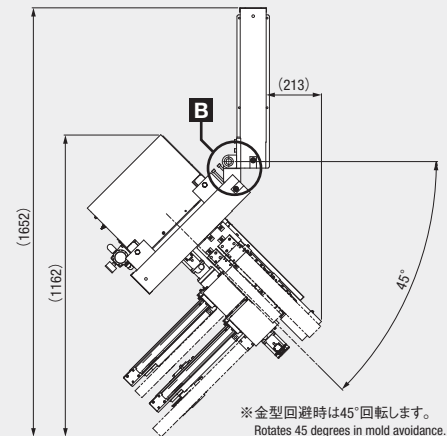
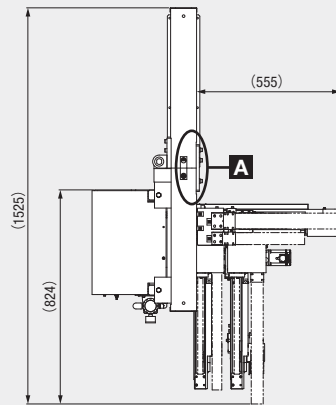

※金型回避時は45°回転します。
Rotates 45 degrees in mold avoidance.

