

SERVICE & SUPPORT

We support stable operation through comprehensive after-sales service after installation.

Should any issues arise, our staff at 16 service locations nationwide will provide prompt support. Maintenance parts are secured the next day for prompt service.



① Izumo Factory



① Headquarters & Factory

Star Seiki products are used throughout the world



North America

1 production plant
7 sales offices

Europe

1 production plant
1 sales office

South America

1 sales office

Asia-Oceania

2 production plants
28 sales offices
1 distributor (Australia)

At our permanent exhibition hall "STAR PLAZA" (Headquarters, Kanto region), you can view our latest Gantry Loaders and efficiency-enhancing equipment.



Keep up to date with all our news

Follow us on social media.



STAR SEIKI CO., LTD.

Head Office & Factory: 3-133, Akita, Ohguchi-cho, Niwa-gun, Aichi Pref., 480-0132 PHONE 0587-95-7551

North America

U.S.A. STAR AUTOMATION, INC. WISCONSIN (HEADQUARTERS)
U.S.A. STAR AUTOMATION, INC. MICHIGAN OFFICE
U.S.A. STAR AUTOMATION, INC. CALIFORNIA OFFICE
U.S.A. STAR AUTOMATION, INC. INDIANA OFFICE

U.S.A. STAR AUTOMATION, INC. GEORGIA OFFICE
U.S.A. STAR AUTOMATION, INC. RHODE ISLAND OFFICE
U.S.A. STAR AUTOMATION, INC. TENNESSEE OFFICE
Mexico STAR SEIKI MEXICO S.A. DE C.V.

South America

Brazil STAR SEIKI BRASIL LTDA.

Europe

Italy STAR AUTOMATION EUROPE S.P.A.

Asia

China STAR SEIKI (SHANGHAI) CO., LTD.
China STAR SEIKI (SHANGHAI) CO., LTD. DALIAN OFFICE
China STAR SEIKI (SHANGHAI) CO., LTD. TIANJIN OFFICE
China STAR SEIKI (SHANGHAI) CO., LTD. QINGDAO OFFICE
China STAR SEIKI (SHANGHAI) CO., LTD. SUZHOU OFFICE
China STAR SEIKI (SHANGHAI) CO., LTD. WUHAN OFFICE
China STAR SEIKI (SHANGHAI) CO., LTD. SHENZHEN BRANCH
China STAR SEIKI (SHANGHAI) CO., LTD. YUYAO OFFICE
China STAR SEIKI (SHANGHAI) CO., LTD. GUANGZHOU OFFICE
China STAR SEIKI (SHANGHAI) CO., LTD. XIAMEN OFFICE
China STAR SEIKI (SHANGHAI) CO., LTD. CHONGQING OFFICE
China STAR SEIKI (SHANGHAI) CO., LTD. CHENGDU OFFICE
China STAR AUTOMATION (SHENZHEN) CO., LTD.
China STAR SEIKI (XIANG YANG) CO., LTD.
China STAR SEIKI (HONGKONG) CO., LTD.
Taiwan STAR SEIKI TAIWAN, INC.

Taiwan STAR SEIKI TAIWAN, INC. TAINAN OFFICE
Taiwan STAR SEIKI TAIWAN, INC. TAICHUNG OFFICE
Korea STAR SEIKI KOREA CO., LTD.
Thailand STAR SEIKI (THAILAND) CO., LTD.
Thailand STAR SEIKI (THAILAND) CO., LTD. PRACHINBURI BRANCH
Singapore STAR SEIKI SINGAPORE PTE. LTD.
Malaysia STAR SEIKI (SINGAPORE) PTE. LTD. K.L. BRANCH
Malaysia STAR SEIKI (SINGAPORE) PTE. LTD. J.B. BRANCH
PT. STAR SEIKI INDONESIA
Indonesia PT. STAR SEIKI INDONESIA BEKASI BRANCH
Indonesia PT. STAR SEIKI INDONESIA SURABAYA BRANCH
Philippines STAR SEIKI PHILIPPINES INC.
Vietnam STAR SEIKI (VIETNAM) CO., LTD.
Vietnam BRANCH OF STAR SEIKI (VIETNAM) CO., LTD. IN HO CHI MINH CITY
India STAR SEIKI INDIA PRIVATE LIMITED
India STAR SEIKI INDIA PRIVATE LIMITED CHENNAI OFFICE

Click here for details



www.starseiki.com



2025.09-EN

Workpiece transfer robot

STAR

Gantry Loader



Proposals Only from Star Seiki, the Comprehensive Cartesian Robot Manufacturer

Robots for rapidly and highly accurately automating processes from material supply to finished product delivery

Product Features

- "3-axis servo drive" including Y-Axis enables flexible automation of both preceding and subsequent processes
- Production and sales track record as a Take-out Robot manufacturer, backed by a reliable support system
- Possible to link with peripheral equipment such as cleaning, dimensional inspection, material supply, and product stock
- Dustproof and splash-proof (IP54)/Wet system only

Our strong points

Flexibly accommodates automation of preceding and subsequent processes and layout changes.

- Possible to link with stock devices/Pallet Changers
- Automates material feeding and transport to two machine tools using a single Gantry Loader.

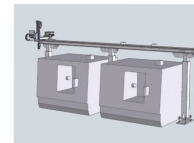

Specification for using two processing machines

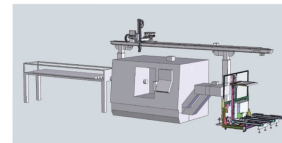

Pallet changer interlock type



STAR SEIKI CO., LTD.

SGLW-807W Wet system

Max. Loading capacity **7kg**® Extract dry cycle **4.48 sec**

SGL-805D Dry system

Max. Loading capacity **5kg**® Extract dry cycle **4.31 sec**

共通仕様 | COMMON SPECIFICATIONS

Power source	Drive system		Standard Air Pressure	posture(option)			Capacity (kVA)	Maximum Power Consumption (KW)
	Traverse	crosswise/vertical		cylinder posture	swivel posture	servo posture(1 axis absolute encoder type)		
AC200V~220V ±10% 50/60Hz	Rack and Pinion	Belt drive	0.5MPa	cylinder posture	swivel posture	servo posture(1 axis absolute encoder type)	2.6	1.5

共通仕様 | COMMON SPECIFICATIONS

Power source	Drive system		Standard Air Pressure	posture(option)			Capacity (kVA)	Maximum Power Consumption (KW)
	Traverse	crosswise/vertical		cylinder posture	swivel posture	servo posture(1 axis absolute encoder type)		
AC200V~220V ±10% 50/60Hz	Rack and Pinion	Belt drive	0.5MPa	cylinder posture	swivel posture	servo posture(1 axis absolute encoder type)	2.6	1.5

総合仕様 | GENERAL SPECIFICATIONS

外形寸法 | OUTER DIMENSIONS

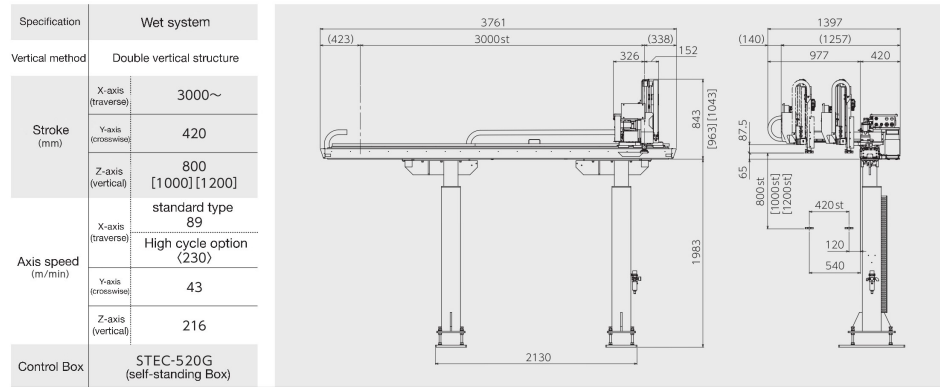

○ Figures in [] shows optional stroke. ○ Figures in () shows High-cycle option specification. ○ Main Loader unit does not include the posture area's loader hand.

総合仕様 | GENERAL SPECIFICATIONS

外形寸法 | OUTER DIMENSIONS

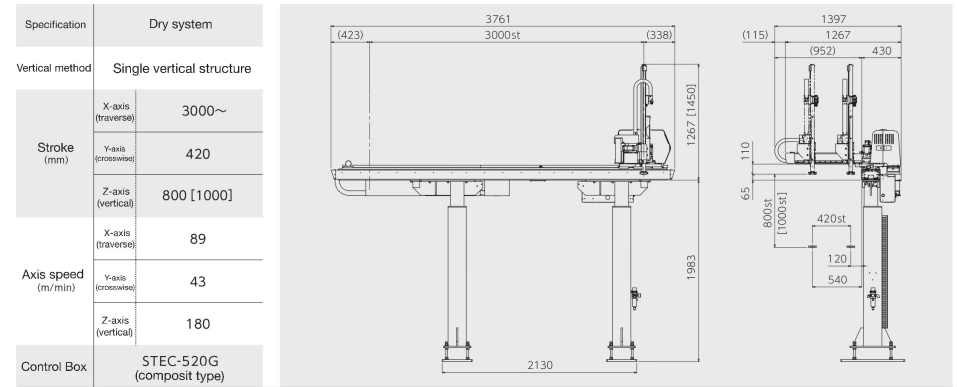

○ Figures in [] shows optional stroke. ○ Figures in () shows High-cycle option specification. ○ Main Loader unit does not include the posture area's loader hand.

SGLW-807D Dry system

Max. Loading capacity **7kg**® Extract dry cycle **4.48 sec**

共通仕様 | COMMON SPECIFICATIONS

Power source	Drive system		Standard Air Pressure	posture(option)			Capacity (kVA)	Maximum Power Consumption (KW)
	Traverse	crosswise/vertical		cylinder posture	swivel posture	servo posture(1 axis absolute encoder type)		
AC200V~220V ±10% 50/60Hz	Rack and Pinion	Belt drive	0.5MPa	cylinder posture	swivel posture	servo posture(1 axis absolute encoder type)	2.6	1.5

総合仕様 | GENERAL SPECIFICATIONS

外形寸法 | OUTER DIMENSIONS

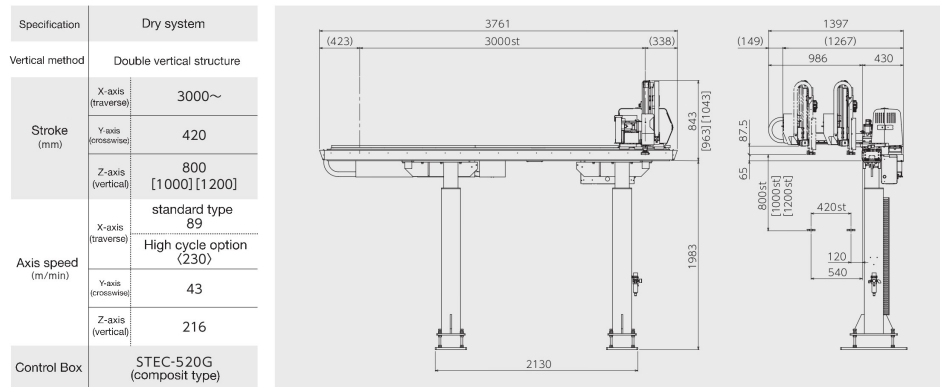

○ Figures in [] shows optional stroke. ○ Figures in () shows High-cycle option specification. ○ Main Loader unit does not include the posture area's loader hand.



Highly operator-friendly controller

STEC-520G

Easy operation via touch screen

USB connection enables flexible data handling

- "STEC-520G", developed through our Take-out Robot, is adopted as the robot control system.
- Operation pendant features a 7-inch wide LCD touch screen for intuitive switching.
- Up to 999 set-up programs can be registered. Program data can be handled via USB connection.
- Enhanced maintenance features include notifications for lubrication and scheduled inspections.

Star Seiki offers the optimal loader hand!

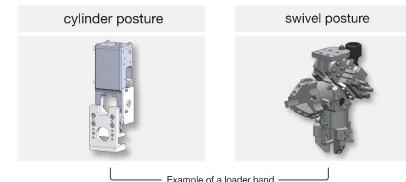

Trust Star Seiki for chucking parts too.

eins アイントップ www.eins.jp



"When you are unsure about hand parts, visit 'Eins' operated by Star Seiki. Depending on your ideas, the possibilities are endless."